

TL497A SWITCHING VOLTAGE REGULATORS

SLVS009D – JUNE 1976 – REVISED JULY 1999

- High Efficiency . . . 60% or Greater
- Output Current . . . 500 mA
- Input Current Limit Protection
- TTL-Compatible Inhibit
- Adjustable Output Voltage
- Input Regulation . . . 0.2% Typ
- Output Regulation . . . 0.4% Typ
- Soft Start-Up Capability

D, N, OR PW PACKAGE
(TOP VIEW)

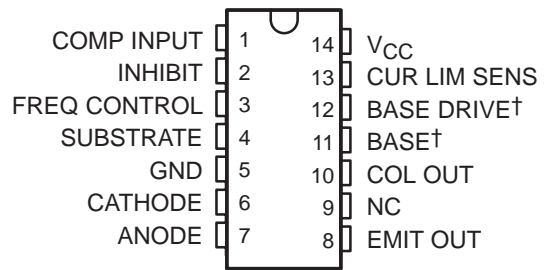

NC – No internal connection

†BASE (11) and BASE DRIVE (12) are used for device testing only. They normally are not used in circuit applications of the device.

description

The TL497A incorporates all the active functions required in the construction of switching voltage regulators. It can also be used as the control element to drive external components for high-power-output applications. The TL497A was designed for ease of use in step-up, step-down, or voltage-inversion applications requiring high efficiency.

The TL497A is a fixed-on-time variable-frequency switching-voltage-regulator control circuit. The switch-on time is programmed by a single external capacitor connected between FREQ CONTROL and GND. This capacitor, C_T , is charged by an internal constant-current generator to a predetermined threshold. The charging current and the threshold vary proportionally with V_{CC} . Thus, the switch-on time remains constant over the specified range of input voltage (4.5 V to 12 V). Typical on times for various values of C_T are as follows:

| TIMING CAPACITOR, C_T (pF) | 200 | 250 | 350 | 400 | 500 | 750 | 1000 | 1500 | 2000 |
|------------------------------|-----|-----|-----|-----|-----|-----|------|------|------|
| ON TIME (μ s) | 19 | 22 | 26 | 32 | 44 | 56 | 80 | 120 | 180 |

The output voltage is controlled by an external resistor ladder network (R1 and R2 in Figures 1, 2, and 3) that provides a feedback voltage to the comparator input. This feedback voltage is compared to the reference voltage of 1.2 V (relative to SUBSTRATE) by the high-gain comparator. When the output voltage decays below the value required to maintain 1.2 V at the comparator input, the comparator enables the oscillator circuit, which charges and discharges C_T as described above. The internal pass transistor is driven on during the charging of C_T . The internal transistor can be used directly for switching currents up to 500 mA. Its collector and emitter are uncommitted, and it is current driven to allow operation from the positive supply voltage or ground. An internal Schottky diode matched to the current characteristics of the internal transistor also is available for blocking or commutating purposes. The TL497A also has on-chip current-limit circuitry that senses the peak currents in the switching regulator and protects the inductor against saturation and the pass transistor against overstress. The current limit is adjustable and is programmed by a single sense resistor, R_{CL} , connected between V_{CC} and CUR LIM SENS. The current-limit circuitry is activated when 0.7 V is developed across R_{CL} . External gating is provided by the INHIBIT input. When the INHIBIT input is high, the output is turned off.

Simplicity of design is a primary feature of the TL497A. With only six external components (three resistors, two capacitors, and one inductor), the TL497A operates in numerous voltage-conversion applications (step-up, step-down, invert) with as much as 85% of the source power delivered to the load. The TL497A replaces the TL497 in all applications.

The TL497AC is characterized for operation from 0°C to 70°C. The TL497AI is characterized for operation from -40°C to 85°C.



Please be aware that an important notice concerning availability, standard warranty, and use in critical applications of Texas Instruments semiconductor products and disclaimers thereto appears at the end of this data sheet.

PRODUCTION DATA information is current as of publication date. Products conform to specifications per the terms of Texas Instruments standard warranty. Production processing does not necessarily include testing of all parameters.

 **TEXAS
INSTRUMENTS**

POST OFFICE BOX 655303 • DALLAS, TEXAS 75265

Copyright © 1999, Texas Instruments Incorporated

TL497A SWITCHING VOLTAGE REGULATORS

SLVS009D – JUNE 1976 – REVISED JULY 1999

AVAILABLE OPTIONS

| T _A | PACKAGED DEVICES | | | CHIP FORM (Y) |
|----------------|-------------------|-----------------|---------------------------|---------------|
| | SMALL-OUTLINE (D) | PLASTIC DIP (N) | SHRINK SMALL-OUTLINE (PW) | |
| 0°C to 70°C | TL497ACD | TL497ACN | TL497ACPW | TL497AY |
| -40°C to 85°C | TL497AID | TL497AIN | — | — |

The D and PW packages are only taped and reeled. Add the suffix R to the device type (e.g., TL497ACPWR). Chip forms are tested at 25°C.

functional block diagram

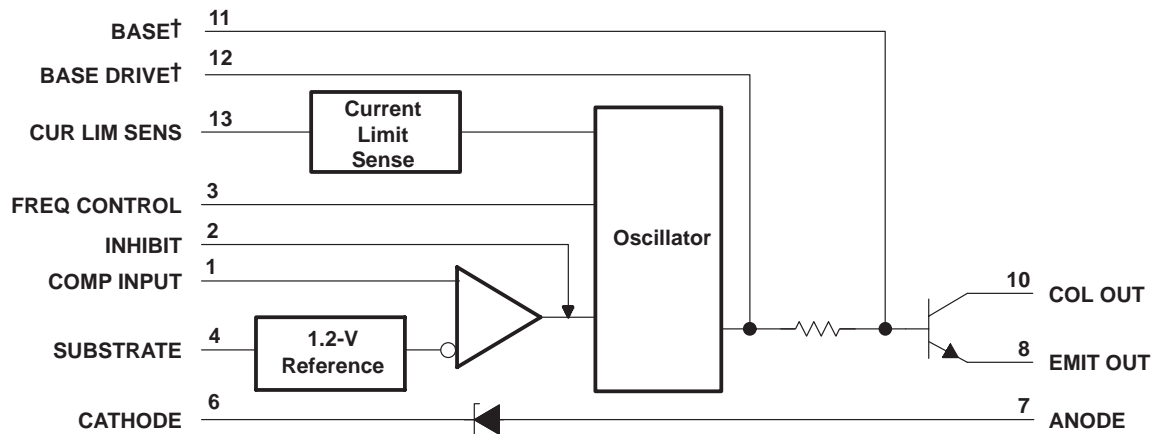

† BASE and BASE DRIVE are used for device testing only. They normally are not used in circuit applications of the device.

TL497A SWITCHING VOLTAGE REGULATORS

SLVS009D – JUNE 1976 – REVISED JULY 1999

absolute maximum ratings over operating free-air temperature range (unless otherwise noted)†

| | |
|---|----------------|
| Supply voltage, V_{CC} (see Note 1) | 15 V |
| Output voltage, V_O | 35 V |
| Input voltage, V_I (COMP INPUT) | 5 V |
| Input voltage, V_I (INHIBIT) | 5 V |
| Diode reverse voltage | 35 V |
| Power switch current | 750 mA |
| Diode forward current | 750 mA |
| Package thermal impedance, θ_{JA} (see Notes 2 and 3): D package | 86°C/W |
| N package | 101°C/W |
| PW package | 113°C/W |
| Lead temperature 1,6 mm (1/16 inch) from case for 60 seconds | 260°C |
| Storage temperature range, T_{stg} | –65°C to 150°C |

†Stresses beyond those listed under “absolute maximum ratings” may cause permanent damage to the device. These are stress ratings only, and functional operation of the device at these or any other conditions beyond those indicated under “recommended operating conditions” is not implied. Exposure to absolute-maximum-rated conditions for extended periods may affect device reliability.

- NOTES:
1. All voltage values except diode voltages are with respect to network ground terminal.
 2. Maximum power dissipation is a function of $T_J(\max)$, θ_{JA} , and T_A . The maximum allowable power dissipation at any allowable ambient temperature is $P_D = (T_J(\max) - T_A)/\theta_{JA}$. Operating at the absolute maximum T_J of 150°C can impact reliability.
 3. The package thermal impedance is calculated in accordance with JESD 51, except for through-hole packages, which use a trace length of zero.

recommended operating conditions

| | | MIN | MAX | UNIT | |
|---|--|------------|-----------|------|----|
| Supply voltage, V_{CC} | | 4.5 | 12 | V | |
| High-level input voltage, V_{IH} | INHIBIT pin | 2.5 | | V | |
| Low-level input voltage, V_{IL} | INHIBIT pin | | 0.8 | V | |
| Output voltage | Step-up configuration (see Figure 1) | $V_I + 2$ | 30 | V | |
| | Step-down configuration (see Figure 2) | V_{ref} | $V_I - 1$ | | |
| | Inverting regulator (see Figure 3) | $-V_{ref}$ | –25 | | |
| Power switch current | | | 500 | mA | |
| Diode forward current | | | 500 | mA | |
| Operating free-air temperature range, T_A | | TL497AC | 0 | 70 | °C |
| | | TL497AI | –40 | 85 | |



TL497A

SWITCHING VOLTAGE REGULATORS

SLVS009D – JUNE 1976 – REVISED JULY 1999

electrical characteristics over recommended operating conditions, $V_{CC} = 6\text{ V}$ (unless otherwise noted)

| PARAMETER | TEST CONDITIONS | T_A † | TL497AC | | | TL497AI | | | UNIT |
|-----------------------------------|---|-----------------------|------------|------|------|---------|------|---------------|---------------|
| | | | MIN | TYP‡ | MAX | MIN | TYP‡ | MAX | |
| High-level input current, INHIBIT | $V_{I(I)} = 5\text{ V}$ | Full range | 0.8 | 1.5 | | 0.8 | 1.5 | mA | |
| Low-level input current, INHIBIT | $V_{I(I)} = 0\text{ V}$ | Full range | 5 | 10 | | 5 | 20 | μA | |
| Comparator reference voltage | $V_I = 4.5\text{ V to }6\text{ V}$ | Full range | 1.08 | 1.2 | 1.32 | 1.14 | 1.2 | 1.26 | V |
| Comparator input bias current | $V_I = 6\text{ V}$ | Full range | 40 | 100 | | 40 | 100 | μA | |
| Switch on-state voltage | $V_I = 4.5\text{ V}$ | $I_O = 100\text{ mA}$ | 25°C | 0.13 | 0.2 | | 0.13 | 0.2 | V |
| | | $I_O = 500\text{ mA}$ | Full range | | 0.85 | | | 1 | |
| Switch off-state current | $V_I = 4.5\text{ V}, V_O = 30\text{ V}$ | 25°C | | 10 | 50 | | 10 | 50 | μA |
| | | Full range | | | 200 | | | 500 | |
| Sense voltage, CUR LIM SENS | $V_I = 6\text{ V}$ | 25°C | 0.45 | | 1 | 0.45 | | 1 | V |
| Diode forward voltage | $I_O = 10\text{ mA}$ | Full range | | 0.75 | 0.85 | | 0.75 | 0.95 | V |
| | $I_O = 100\text{ mA}$ | Full range | | 0.9 | 1 | | 0.9 | 1.1 | |
| | $I_O = 500\text{ mA}$ | Full range | | 1.33 | 1.55 | | 1.33 | 1.75 | |
| Diode reverse voltage | $I_O = 500\text{ }\mu\text{A}$ | Full range | | | | 30 | | | V |
| | $I_O = 200\text{ }\mu\text{A}$ | Full range | 30 | | | | | | |
| On-state supply current | | 25°C | | 11 | 14 | | 11 | 14 | mA |
| | | Full range | | | 15 | | | 16 | |
| Off-state supply current | | 25°C | | 6 | 9 | | 6 | 9 | mA |
| | | Full range | | | 10 | | | 11 | |

† Full range is 0°C to 70°C for the TL497AC and –40°C to 85°C for the TL497AI.

‡ All typical values are at $T_A = 25^\circ\text{C}$.

electrical characteristics over recommended operating conditions, $V_{CC} = 6\text{ V}$, $T_A = 25^\circ\text{C}$ (unless otherwise noted)

| PARAMETER | TEST CONDITIONS | TL497AY | | | UNIT |
|-----------------------------------|---|---------|------|-----|---------------|
| | | MIN | TYP | MAX | |
| High-level input current, INHIBIT | $V_{I(I)} = 5\text{ V}$ | | 0.8 | | mA |
| Low-level input current, INHIBIT | $V_{I(I)} = 0\text{ V}$ | | 5 | | μA |
| Comparator reference voltage | $V_I = 4.5\text{ V to }6\text{ V}$ | | 1.2 | | V |
| Comparator input bias current | $V_I = 6\text{ V}$ | | 40 | | μA |
| Switch on-state voltage | $V_I = 4.5\text{ V}, I_O = 100\text{ mA}$ | | 0.13 | | V |
| Switch off-state current | $V_I = 4.5\text{ V}, V_O = 30\text{ V}$ | | 10 | | μA |
| Diode forward voltage | $I_O = 10\text{ mA}$ | | 0.75 | | V |
| | $I_O = 100\text{ mA}$ | | 0.9 | | |
| | $I_O = 500\text{ mA}$ | | 1.33 | | |
| On-state supply current | | | 11 | | mA |
| Off-state supply current | | | 6 | | mA |



APPLICATION INFORMATION

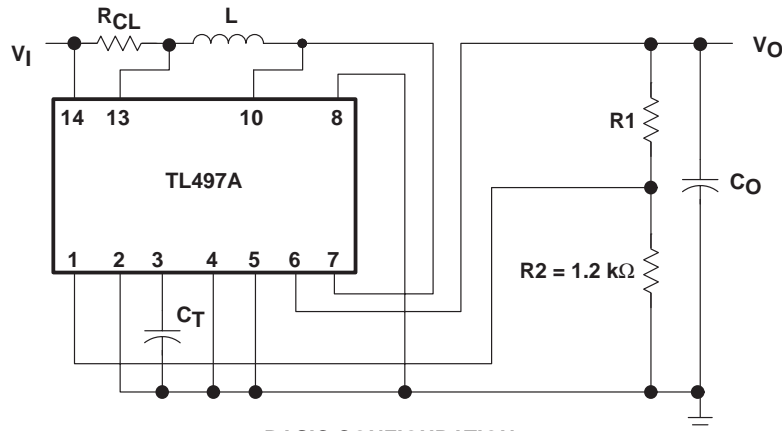

BASIC CONFIGURATION
(Peak Switching Current = $I_{(PK)} < 500 \text{ mA}$)

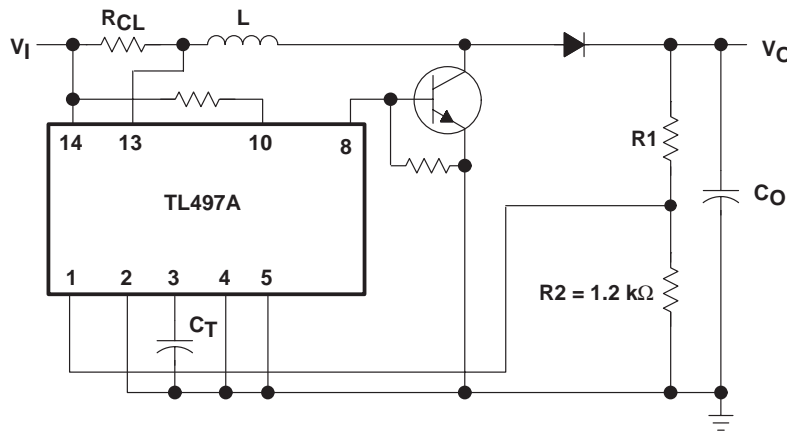

EXTENDED POWER CONFIGURATION
(using external transistor)

DESIGN EQUATIONS

- $I_{(PK)} = 2 I_O \max \left[\frac{V_O}{V_I} \right]$

- $L (\mu\text{H}) = \frac{V_I}{I_{(PK)}} t_{on} (\mu\text{s})$

Choose L (50 to 500 μH), calculate t_{on} (25 to 150 μs)

- $C_T (\text{pF}) \approx 12 t_{on} (\mu\text{s})$

- $R_1 = (V_O - 1.2 \text{ V}) \text{ k}\Omega$

- $R_{CL} = \frac{0.5 \text{ V}}{I_{(PK)}}$

- $C_O (\mu\text{F}) \approx t_{on} (\mu\text{s}) \frac{\left[\frac{V_I}{V_O} I_{(PK)} + I_O \right]}{V_{\text{ripple (PK)}}$

Figure 1. Positive Regulator, Step-Up Configurations

TL497A SWITCHING VOLTAGE REGULATORS

SLVS009D – JUNE 1976 – REVISED JULY 1999

APPLICATION INFORMATION

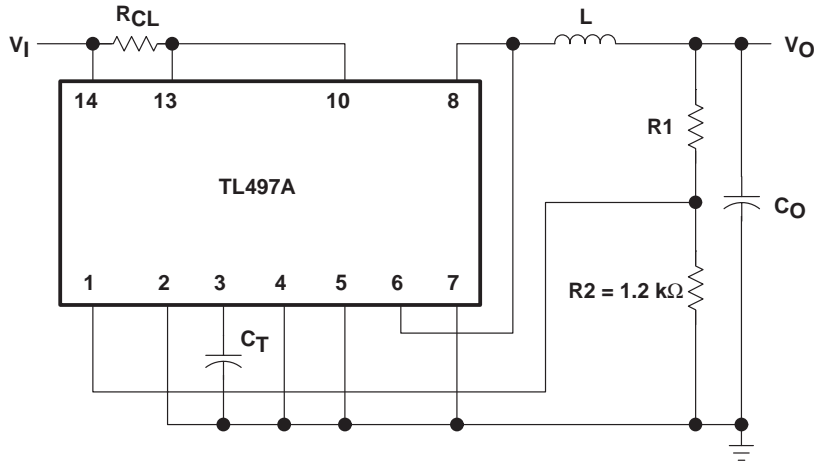

BASIC CONFIGURATION
(Peak Switching Current = $I_{(PK)} < 500 \text{ mA}$)

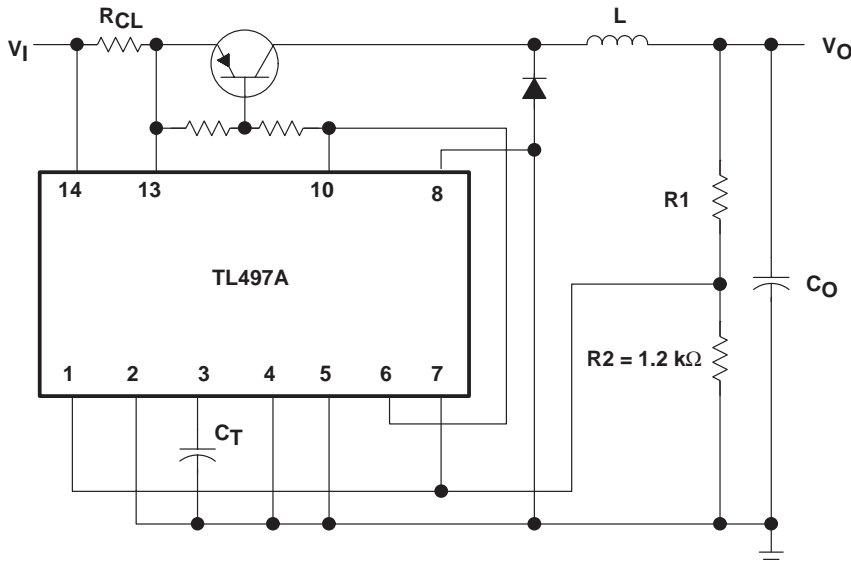

EXTENDED POWER CONFIGURATION
(using external transistor)

DESIGN EQUATIONS

- $I_{(PK)} = 2 I_{O \text{ max}}$

- $L (\mu\text{H}) = \frac{V_I - V_O}{I_{(PK)}} t_{on}(\mu\text{s})$

Choose L (50 to 500 μH), calculate t_{on} (10 to 150 μs)

- $C_T(\text{pF}) \approx 12 t_{on}(\mu\text{s})$

- $R1 = (V_O - 1.2 \text{ V}) \text{ k}\Omega$

- $R_{CL} = \frac{0.5 \text{ V}}{I_{(PK)}}$

- $C_O (\mu\text{F}) \approx t_{on}(\mu\text{s}) \frac{\left[\frac{V_I - V_O}{V_O} I_{(PK)} + I_O \right]}{V_{\text{ripple}}(\text{PK})}$

Figure 2. Positive Regulator, Step-Down Configurations

APPLICATION INFORMATION

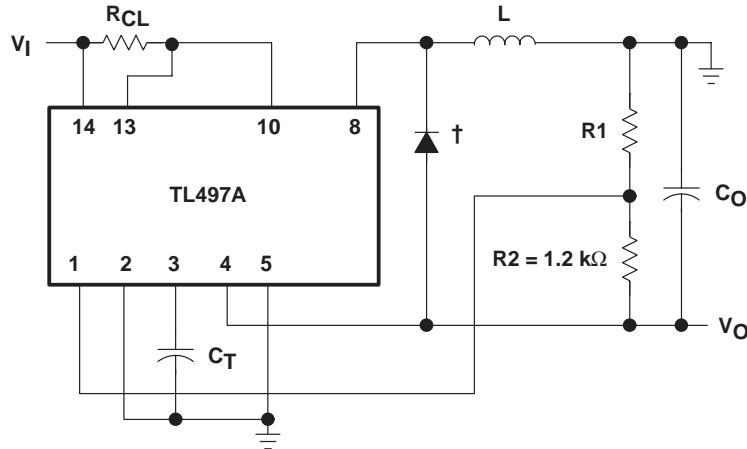

BASIC CONFIGURATION
(Peak Switching Current = $I_{(PK)} < 500 \text{ mA}$)

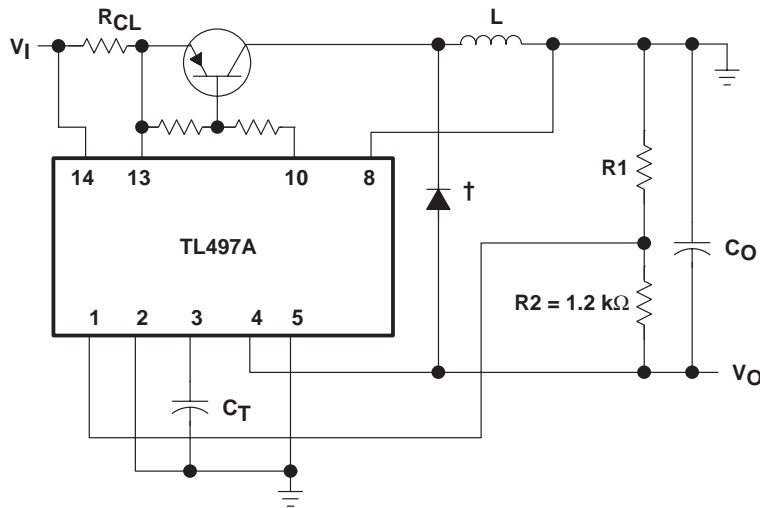

EXTENDED POWER CONFIGURATION
(using external transistor)

DESIGN EQUATIONS

- $I_{(PK)} = 2 I_O \max \left[1 + \frac{|V_O|}{V_I} \right]$

- $L (\mu\text{H}) = \frac{V_I}{I_{(PK)}} t_{on}(\mu\text{s})$

Choose L (50 to 500 μH), calculate t_{on} (10 to 150 μs)

- $C_T(\text{pF}) \approx 12 t_{on}(\mu\text{s})$

- $R_1 = (|V_O| - 1.2 \text{ V}) \text{ k}\Omega$

$$R_{CL} = \frac{0.5 \text{ V}}{I_{(PK)}}$$

- $C_O (\mu\text{F}) \approx t_{on}(\mu\text{s}) \frac{\left[\frac{V_I}{|V_O|} I_{(PK)} + I_O \right]}{V_{\text{ripple (PK)}}$

† Use external catch diode, e.g., 1N4001, when building an inverting supply with the TL497A.

Figure 3. Inverting Applications

TL497A SWITCHING VOLTAGE REGULATORS

SLVS009D – JUNE 1976 – REVISED JULY 1999

APPLICATION INFORMATION

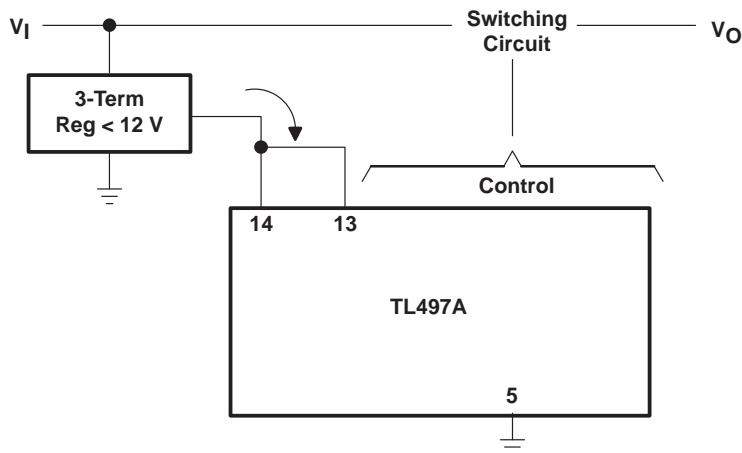

EXTENDED INPUT CONFIGURATION WITHOUT CURRENT LIMIT

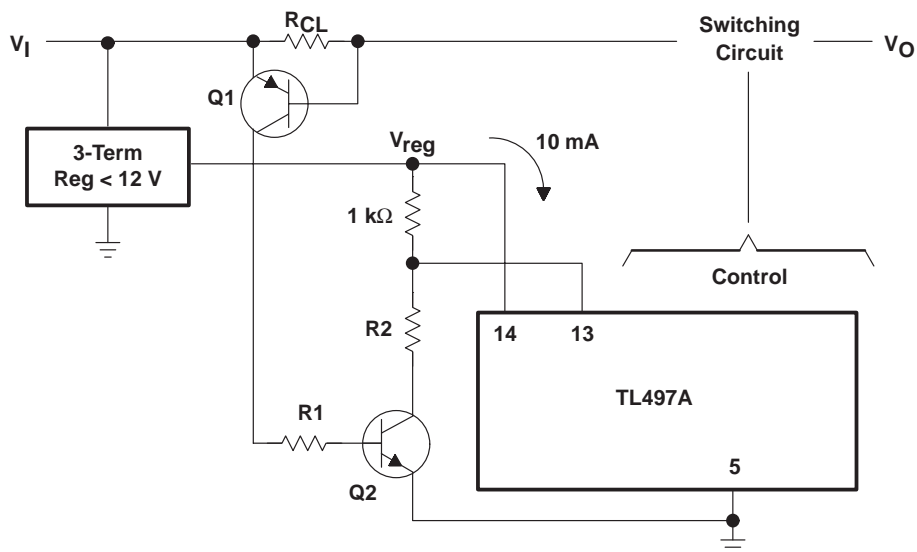

DESIGN EQUATIONS

- $R_{CL} = \frac{V_{BE(Q1)}}{I_{limit}(PK)}$
- $R1 + \frac{V_I}{I_B(Q2)}$
- $R2 = (V_{reg} - 1) 10 \text{ k}\Omega$

CURRENT LIMIT FOR EXTENDED INPUT CONFIGURATION

Figure 4. Extended Input Voltage Range ($V_I > 12 \text{ V}$)

IMPORTANT NOTICE

Texas Instruments and its subsidiaries (TI) reserve the right to make changes to their products or to discontinue any product or service without notice, and advise customers to obtain the latest version of relevant information to verify, before placing orders, that information being relied on is current and complete. All products are sold subject to the terms and conditions of sale supplied at the time of order acknowledgement, including those pertaining to warranty, patent infringement, and limitation of liability.

TI warrants performance of its semiconductor products to the specifications applicable at the time of sale in accordance with TI's standard warranty. Testing and other quality control techniques are utilized to the extent TI deems necessary to support this warranty. Specific testing of all parameters of each device is not necessarily performed, except those mandated by government requirements.

CERTAIN APPLICATIONS USING SEMICONDUCTOR PRODUCTS MAY INVOLVE POTENTIAL RISKS OF DEATH, PERSONAL INJURY, OR SEVERE PROPERTY OR ENVIRONMENTAL DAMAGE ("CRITICAL APPLICATIONS"). TI SEMICONDUCTOR PRODUCTS ARE NOT DESIGNED, AUTHORIZED, OR WARRANTED TO BE SUITABLE FOR USE IN LIFE-SUPPORT DEVICES OR SYSTEMS OR OTHER CRITICAL APPLICATIONS. INCLUSION OF TI PRODUCTS IN SUCH APPLICATIONS IS UNDERSTOOD TO BE FULLY AT THE CUSTOMER'S RISK.

In order to minimize risks associated with the customer's applications, adequate design and operating safeguards must be provided by the customer to minimize inherent or procedural hazards.

TI assumes no liability for applications assistance or customer product design. TI does not warrant or represent that any license, either express or implied, is granted under any patent right, copyright, mask work right, or other intellectual property right of TI covering or relating to any combination, machine, or process in which such semiconductor products or services might be or are used. TI's publication of information regarding any third party's products or services does not constitute TI's approval, warranty or endorsement thereof.