

SINGLE CHANNEL IL766 DUAL CHANNEL ILD766

Bidirectional Input Darlington Optocoupler

FEATURES

- Internal R_{BE} for Better Stability
- High Current Transfer Ratios, $V_{CE}=5.0\text{ V}$
IL/ILD766-1: 500% at $I_F=2.0\text{ mA}$
IL/ILD766-2: 500% at $I_F=1.0\text{ mA}$
- $BV_{CEO} > 60\text{ V}$
- AC or Polarity Insensitive Inputs
- Built-In Reverse Polarity Input Protection
- Industry Standard DIP Package
- Underwriters Lab File #E52744

DESCRIPTION

The IL/ILD766 are bidirectional input optically coupled isolators. They consist of two Gallium Arsenide infrared emitting diodes coupled to a silicon NPN photodarlington per channel.

The IL766 are single channel optocouplers. The ILD766 has two isolated channels in a single DIP package. They are designed for applications requiring detection or monitoring of AC signals.

Maximum Ratings

Emitter (Each Channel)

Continuous Forward Current	60 mA
Power Dissipation at 25°C	
Single Channel	200 mW
Dual Channel	90 mW
Derate Linearly from 25°C	
Single Channel	2.6 mW/°C
Dual Channel	1.2 mW/°C

Detector (Each Channel)

Collector-Emitter Breakdown Voltage	60 V
Collector-Base Breakdown Voltage	70 V
Power Dissipation at 25°C	100 mW
Derate Linearly from 25°C	1.33 mW/°C

Package

Isolation Test Voltage ($t=1.0\text{ sec.}$)	7500 VAC _{PK} /5300 V _{RMS}
Isolation Resistance	
$T_A=25^\circ\text{C}$	$\geq 10^{12}\ \Omega$
$T_A=100^\circ\text{C}$	$\geq 10^{11}\ \Omega$
Total Power Dissipation at $T_A=25^\circ\text{C}$ (LED Plus Detector)	
Single Channel	250 mW
Dual Channel	400 mW
Derate Linearly from 25°C	
Single Channel	3.3 mW/°C
Dual Channel	5.3 mW/°C
Creepage	7.0 mm min.
Clearance	7.0 mm min.
Comparative Tracking Index per DIN IEC 112/VDE303, part 1	175
Storage Temperature	-55°C to +150°C
Operating Temperature	-55°C to +100°C
Lead Soldering Time at 260°C	10 sec.

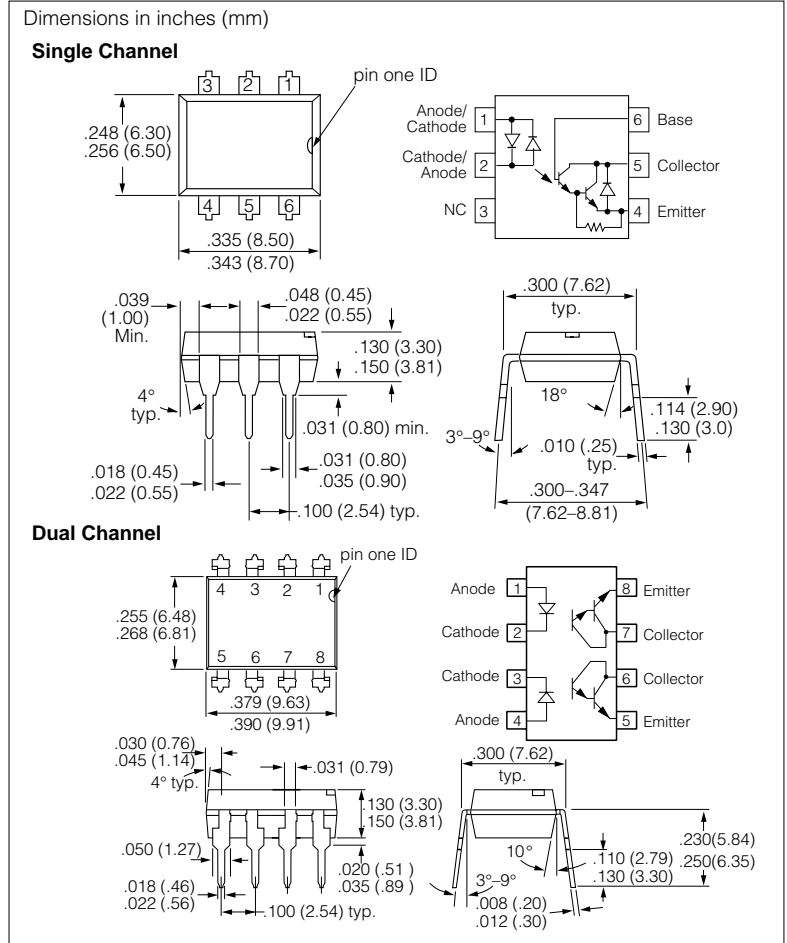

Electrical Characteristics $T_A=25^\circ\text{C}$

Parameter	Sym	Min	Typ	Max	Unit	Condition
Emitter						
Forward Voltage	V_F	—	1.2	1.5	V	$I_F=\pm 10\text{ mA}$
Detector						
Breakdown Voltage, Collector-Emitter	BV_{CEO}	60	75	—	V	$I_C=1.0\text{ mA}$
Collector-Base	BV_{CBO}	60	90	—	V	$I_C=10\ \mu\text{A}$
Leakage Current, Collector-Emitter	I_{CEO}	—	10	100	nA	$V_{CE}=10\text{ V}$
Package						
Saturation Voltage, Collector-Emitter	V_{CEsat}	—	—	1.0	V	$I_F=\pm 10\text{ mA}$ $I_C=10\text{ mA}$
DC Current Transfer Ratio IL766/ILD766-1	CTR	500	—	—	%	$V_{CE}=5.0\text{ V}$ $I_F=\pm 2.0\text{ mA}$
IL766-2		500	—	—	%	$I_F=\pm 1.0\text{ mA}$
Rise Time, Fall Time	—	—	100	—	μs	$V_{CC}=10\text{ V}$ $I_F=\pm 2.0\text{ mA}$ $R_L=100\ \Omega$

Figure 1. Input characteristics

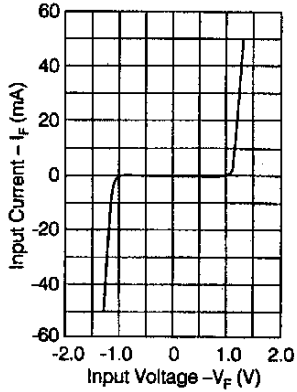

Figure 2. Transistor current versus voltage

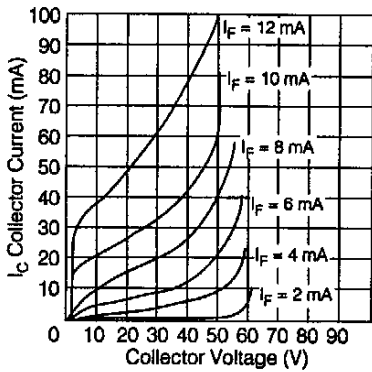

Figure 3. Transistor output current versus voltage

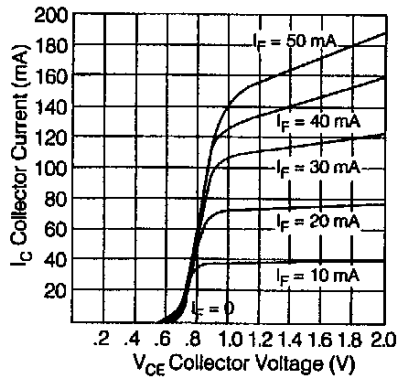

Figure 4. I_{CEO} at $V_{CE}=10\text{ V}$ versus temperature

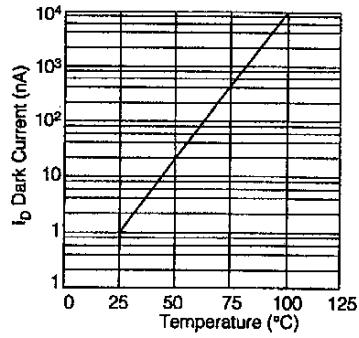

Figure 5. Normalized CTR versus forward current

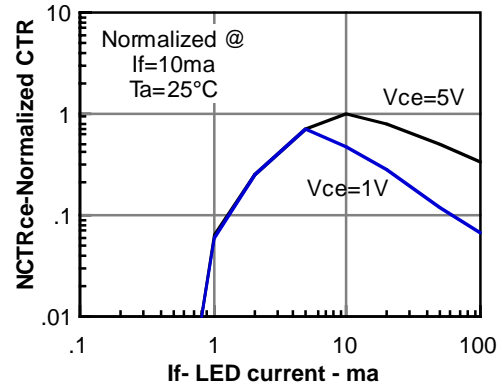

Figure 6. t_r versus forward current

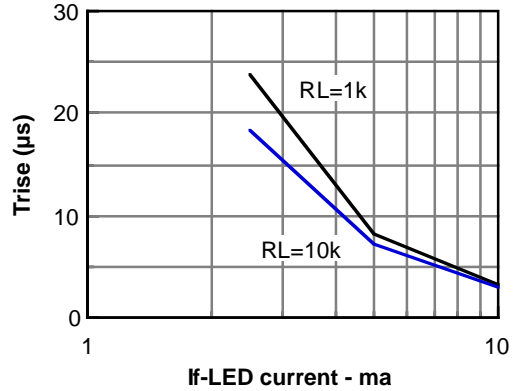

Figure 7. Saturated switching characteristics measurements—schematic and waveform

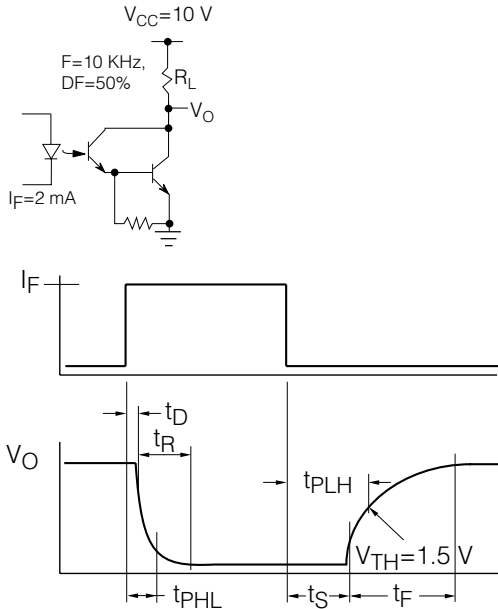

Figure 8. t_{fall} versus forward current

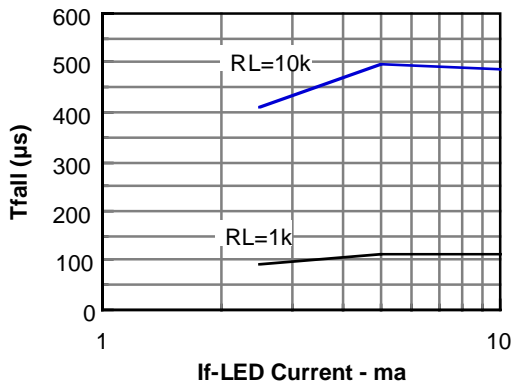

Figure 9. t_{on} versus forward current

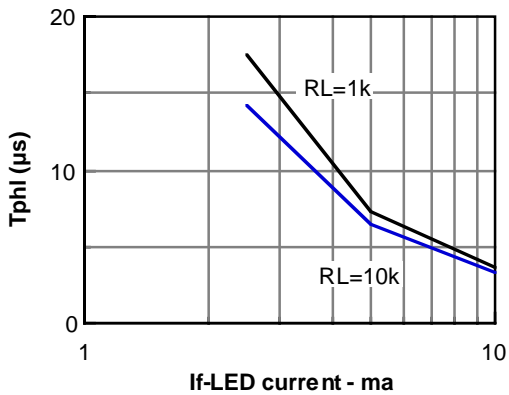

Figure 10. t_{off} versus forward current

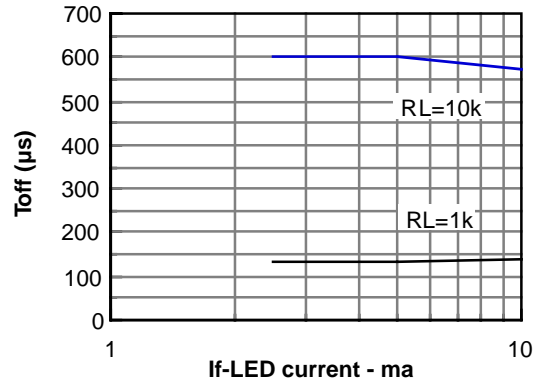

Figure 11. t_{phl} versus forward current

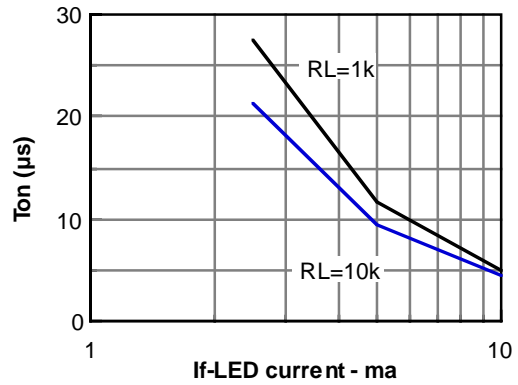

Figure 12. t_{plh} versus forward current

